

# AMERICAN PRO

**BLACK-6 BLACK-12 BLACK-14**



**PROFESSIONAL AUDIO MIXER**



# Contents

Before operating, please read this manual completely.

<b>Mono input channels.....</b>	<b>1</b>
<b>OUTPUT CHANNELS .....</b>	<b>5</b>
<b>Specifications.....</b>	<b>7</b>
<b>System block diagram.....</b>	<b>8</b>
<b>Warning and attention.....</b>	<b>9</b>

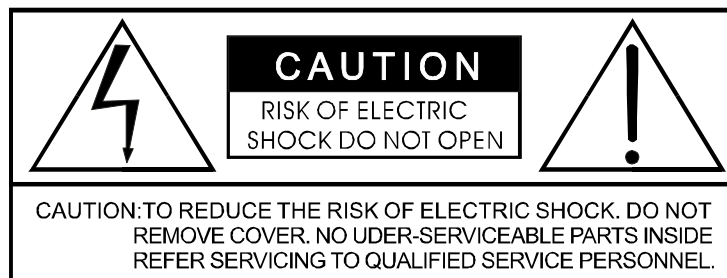

<http://www.americanpro-audio.com>

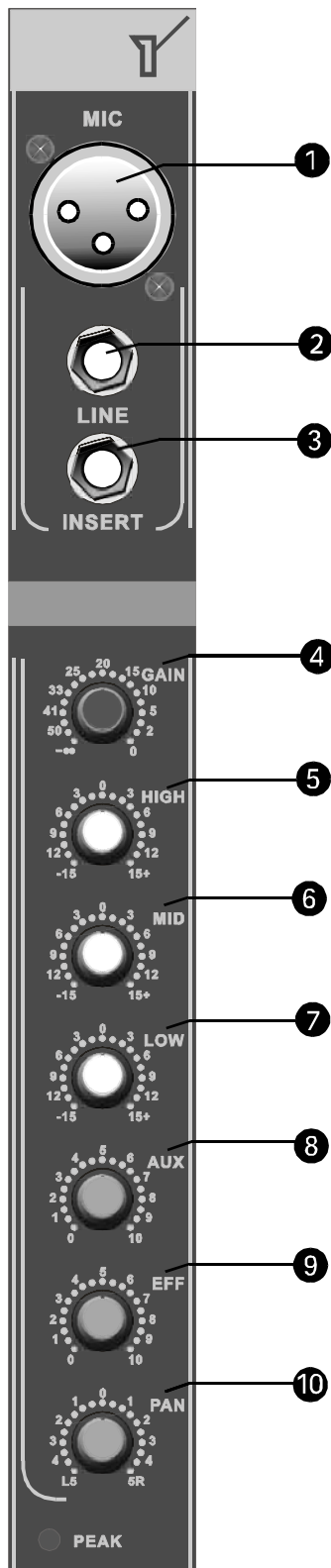

## FRONT PANEL CONTROLS

### 1 MIC

These are to be connected with microphone XLR Jacks are used for the balanced signal

### 2 LINE

These are to be connected with these line sources such as deck tuner turntable keyboard etc

### 3 INSERT

The INSERT is a break point in the input channel signal path. It allows the signal to be taken out from the mixer, through an external equipment such as a compressor, and then back to continue the final mix output.

### 4 GAIN

This has a function which adjusts the input sensitivity of each channel in order to input the constant level of the signal

### 5 HIGH

This has a function which controls the high frequency tone of each channel . Always set this control to the 12 o'clock position, but you can control the high frequency tone according to the speaker the conditions of listening position and listener's taste. Clockwise rotation of the control increases level, and vice versa

### 6 MIDDLE

This has a function which controls the middle frequency tone of each channel. Always set this control to the clock position, but you can control the middle frequency of listening position and listener's taste. Clockwise rotation of the control increases the level, and vice versa.

### 7 LOW

This has a function which controls the low frequency tone of each channel. Always set this control the 12 o'clock position, but you can control the low frequency tone accorg to the speaker, the conditions of listening position and listener's taste. Clockwise rotation of the control increases the level, and vice versa.

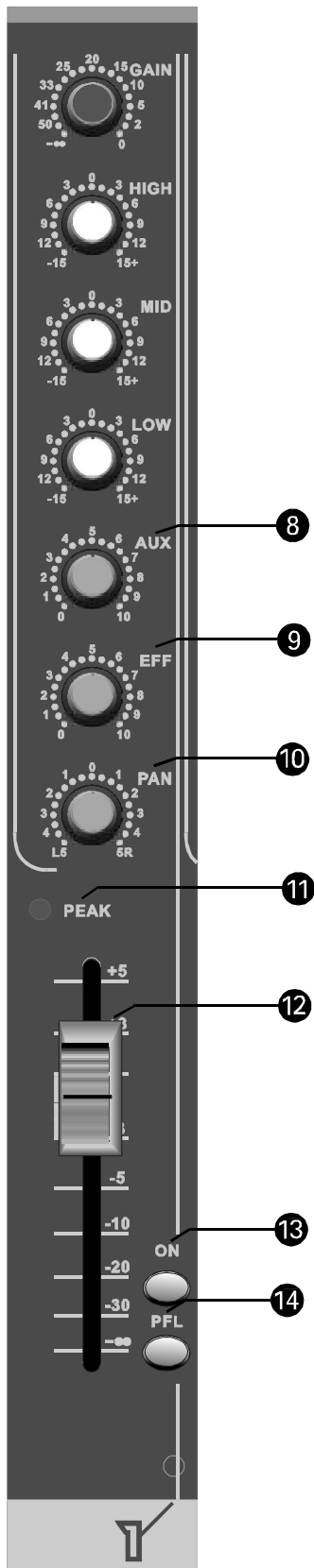

## 8 AUX

This rotary fader sends out the channel signal to AUX bus. The signal is pre-fader so that the aux send to be independent of the fader; this is suitable for foldback or monitor.

## 9 EFFECT

When you want to get echo effect of each channel, you can adjust the level of installed echo by this.

(Unless you will use echo on any channel, turn to "0" Position of MON control at that channel.)

## 10 PAN

This has a function which distributes the signal level between left and right channels to make a stereo sound effect.

## 11 PEAK

This is the lamp which indicates the input signal level of this appliance (regardless of output) when GAIN volume is adjusted.

## 12 CHANNEL VOLUME

These are used for adjusting the volume of signal sources, which are connected to the relevant channels.

## 13 ON

This switch is used to turn the channel on and off. When the switch is in the raised position the channel is OFF. When the switch is depressed the channel is ON. When the channel is turned OFF the feeds to aux, and to the groups and masters are muted.

## 14 PFL

You can monitor the signal of the only channel on which PFL switch is turned "ON" through the headphone. (In this time, the other channels are automatically cut off.)

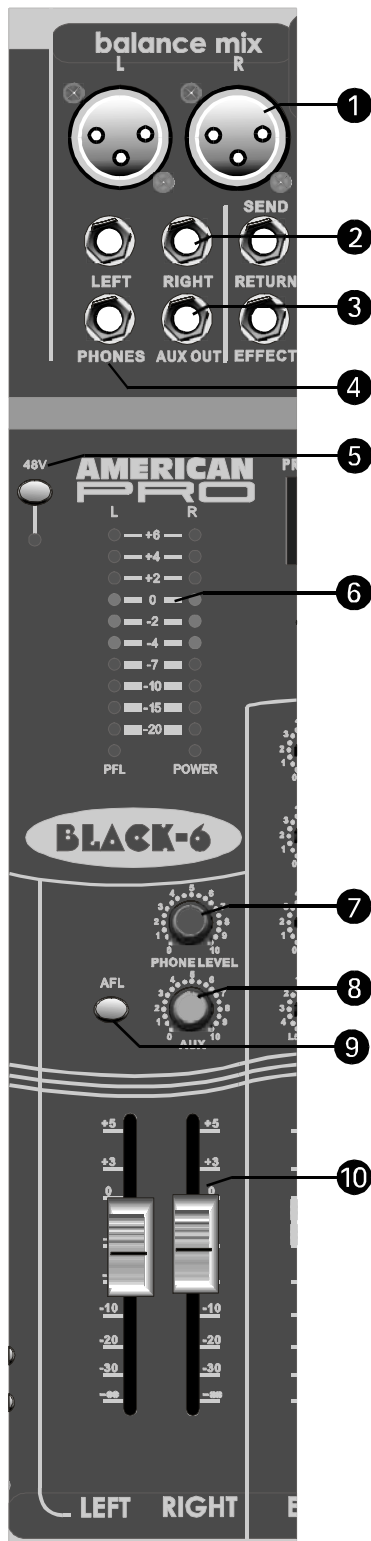

### 1 BALANCE OUTPUT

These are jacks to send the finally mixed outputs to the other appliance (amplifier).

### 2 UNBALANCE OUTPUT

These are jacks to send the finally mixed outputs to the other appliance (amplifier).

### 3 AUX OUT

This jack is to be connected with the input jack of AUX amplifier when using separate AUX amplifier.

### 4 HEADPHONE JACK

This is used for monitoring the master signal and individually monitoring each channel with PFL S/W.

### 5 HEADPHONE LEVEL

These are used for adjusting volume of headphone out put.

### 6 +48V PHANTOM

This slide-switch turns the master phantom power on and off.

### 7 LEVEL METER

This is a lamp which indicates output levels of left and right channel and operating conditions of the appliance, thus you can see all output conditions with your eyes.

Make sure the output levels should not exceed the LED indicator.

### 8 AUX LEVEL

These are used for adjusting volume of AUX out put.

### 9 PFL SELECT BUTTON

Push down to select the phone level to send out L/R signals level of PFL signals.

### 10 MASTER VOLUME (L/R)

This is used for adjusting volume of finally mixed out puts (L & R) and sending the relevant signals to input channel of main amplifier.

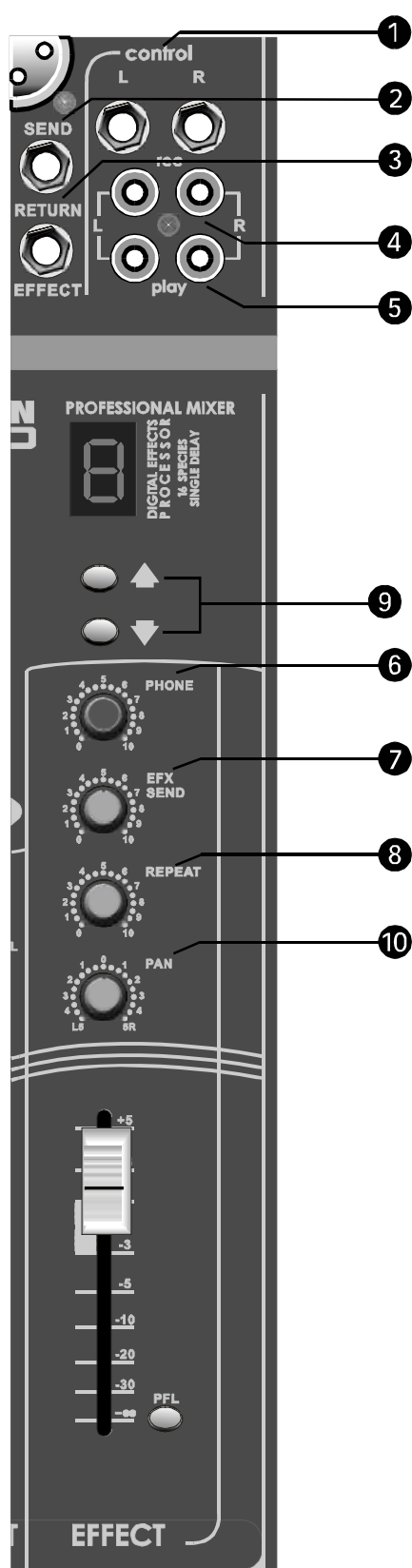

**1 CTRL RM**

This jack is to be connected with the input jack of monitor amp lifier when using separate monitor amplifier.

**2 EFF SEND**

These are to be connected with external digital rever & effect equipment.

**3 EFF RETURN**

These are to be connected with external digital reverb & effect equipment.

**4 RECORD PIN JACK**

This jack is to be connected with cassette deck when recording the mixed output.

**5 PLAY PIN JACK**

This jack is to be connected with cassette deck when playing back.

**6 PLAY**

You can adjust the volume of AUX IN signal by this when connecting AUX IN.

**7 EFF SEND**

This is used for adjusting volume of echo sound when sending echo sound to SEND jack.

**8 REPEAT**

This is used for adjusting frequency of echo repeat. Since too much echo repeat may cause a howl. Please adjust frequency properly.

**9 DELAY**

This is used for adjusting the time interval of echo repeat. The middle position (5) may be most effective.

**10 PAN**

This has a function which distributes the signal level between left and right channels to make a stereo sound effect.

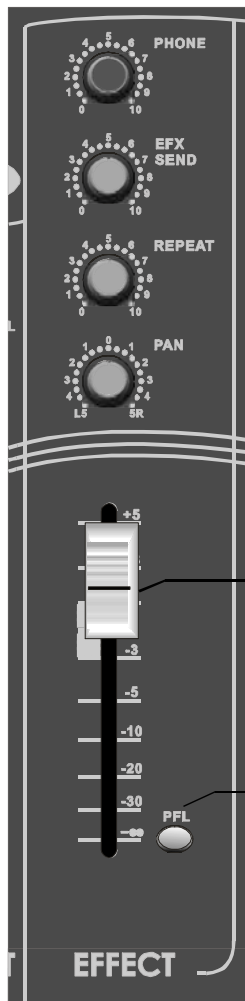

## 11 PFL

When you want to monitor echo sound & external effector sound, you can adjust this control through the headphone.

## 12 EFF/RETURN

This is used for adjusting volume of echo sound when connecting sound to RETURN jack..



## 1 POWER SUPPLY INPUT SOCKET

Connect the power supply unit to this socket. Make sure the power supply unit is not plugged into mains before connecting to the mixer.

## 2 POWER ON/OFF SWITCH

This switch turn on and off the power of the unit.



## SPECIFICATIONS

MODEL CONDITON	6 channel / 8 channel / 12 channel
Input Sensitivity	-60dBm~-40dBm
Nominsl Input Level	Mic-60dBm Line-20dBm Eff Ret-20dB Aux In-20dB Tape In-10dB
Nominsl Output Level	Eff Send-10dBm Aux Send 0dBm
Common Mode Rejection	-70dB
Output Voltage (mixer part)	4V Max
S/N Ratio	≥ 80dB
THD(1KHz Full Power)	Less than 0.03% (at 1KHz)
Frequency Resposne	20Hz-20KHz*3dB
Headphone	7V/220Ω
Parametric EQ	Hi*15dB/12KHz Mid*15dB/2.5K Low*15dB/80KHz
Power Conaumption	30W
Power Supply	AC 220-240V / 50-60Hz

# BLOCK DIAGRAM

